

## GRADE 8 HEX FLANGE NUTS

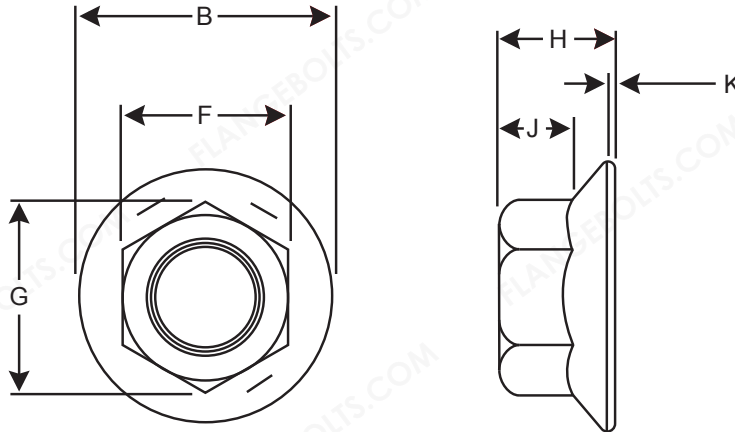

Nominal Size or Basic Bolt Diameter	F		G		B		H		J	K
	Width Across Flats		Width Across Corners		Flange Dia		Nut Thickness		Wrench Height	Flange Thickness
	Max	Min	Max	Min	Max	Min	Max	Min	Min	Min
1/4	0.438	0.428	0.505	0.488	0.594	0.574	0.236	0.222	0.14	0.04
5/16	0.500	0.489	0.577	0.557	0.680	0.660	0.283	0.268	0.17	0.04
3/8	0.562	0.551	0.650	0.628	0.750	0.728	0.347	0.330	0.23	0.04
7/16	0.688	0.675	0.794	0.768	0.937	0.910	0.395	0.375	0.26	0.04
1/2	0.750	0.736	0.866	0.840	1.031	1.000	0.458	0.437	0.31	0.05
5/8	0.938	0.922	1.083	1.051	1.281	1.248	0.569	0.545	0.40	0.05
3/4	1.125	1.088	1.299	1.240	1.500	1.460	0.675	0.627	0.46	0.06

### SPECIFICATIONS

MATERIAL: GRADE 8 PER SAE J995

HARDNESS: 1/4"-5/8" 24-32HRC & 3/4" 26-34HRC

DIMENSIONS: IFI-145 (2002) OR ASME B18.2.2 (2011)

FINISH: PHOSPHATE & OIL